

Hybrid Pro 20FT Modular Backwall Kit 36

HP-K-36

Hybrid Pro™ Modular Kit 36 mixes fabric, form and function! This 20ft wide dynamic display features Blaze™ Light Boxes on both ends plus MODify™ merchandising walls and shelving. All panels have SEG push-fit fabric graphics for promotion and branding, which are easy to change out. This helps extend the longevity of the display, which can be used for both tradeshow and retail applications.



We are continually improving and modifying our product range and reserve the right to vary the specifications without prior notice. All dimensions and weights quoted are approximate and we accept no responsibility for variance. E&OE. See Graphic Templates for graphic bleed specifications

features and benefits:

- Silver aluminum extrusion frames
- 2 light boxes, one on each end
- 4 silver steel shelves and 2 silver base decks for merchandising
- 5 single-sided SEG dye-sublimated push-fit fabric graphics, 2 illuminated, 3 non
- Cases included: OCH2@ (4)
- Lifetime hardware warranty against manufacturer defects

dimensions:

Hardware

Assembled unit:

237.79" w x 94.50" h x 29.72" d
6,038mm(w) x 2400mm(h) x 756(d)

Approximate Weight:
388 lbs / 176 kg

Graphics

Refer to related graphic templates for more information Visit:

<https://www.theexhibitorshandbook.com/downloads/download-graphic-templates> or click here

Shipping

Packing case(s):
4 OCH2

Shipping dimensions:
OCH2:
(52" L x 29" H x 15" D)
1448mm(l) x 1449mm(h) x 838mm(d)

Approximate shipping weight:
507 lbs / 230 kg



This product may include the following materials for recycle: aluminum, select wood, fabric, cardboard, paper, steel, and plastics.

additional information:

Graphic material:

Dye-sublimation SEG push-fit fabric

2 person assembly recommended:



HP-K-36

SETUP INSTRUCTIONS

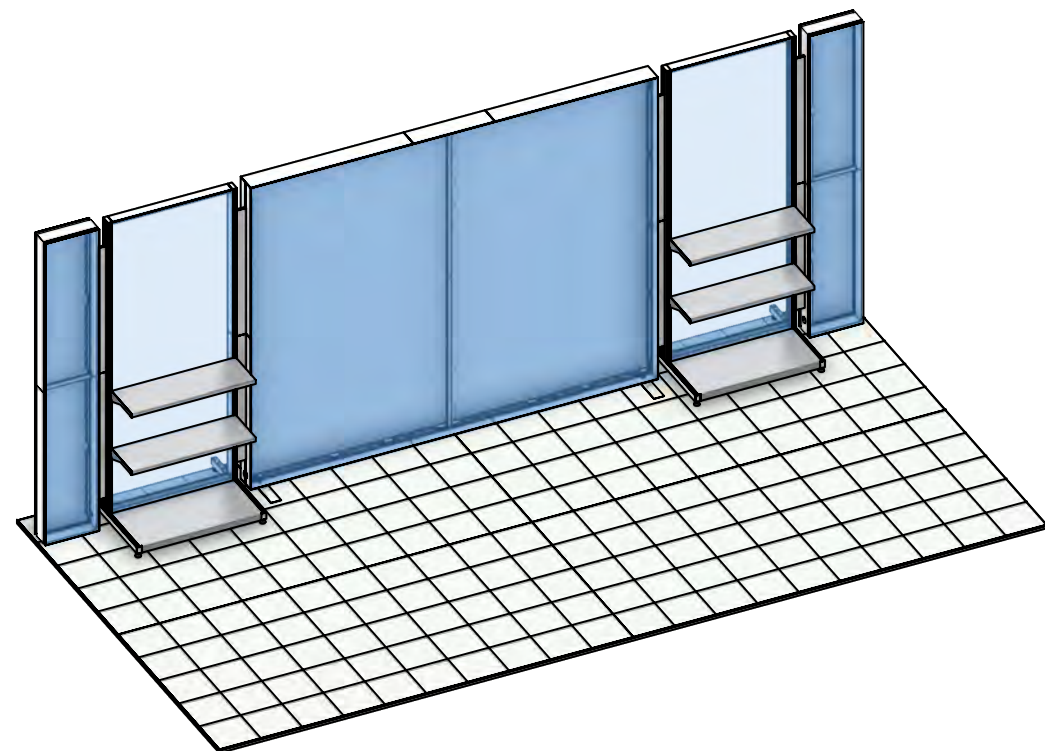
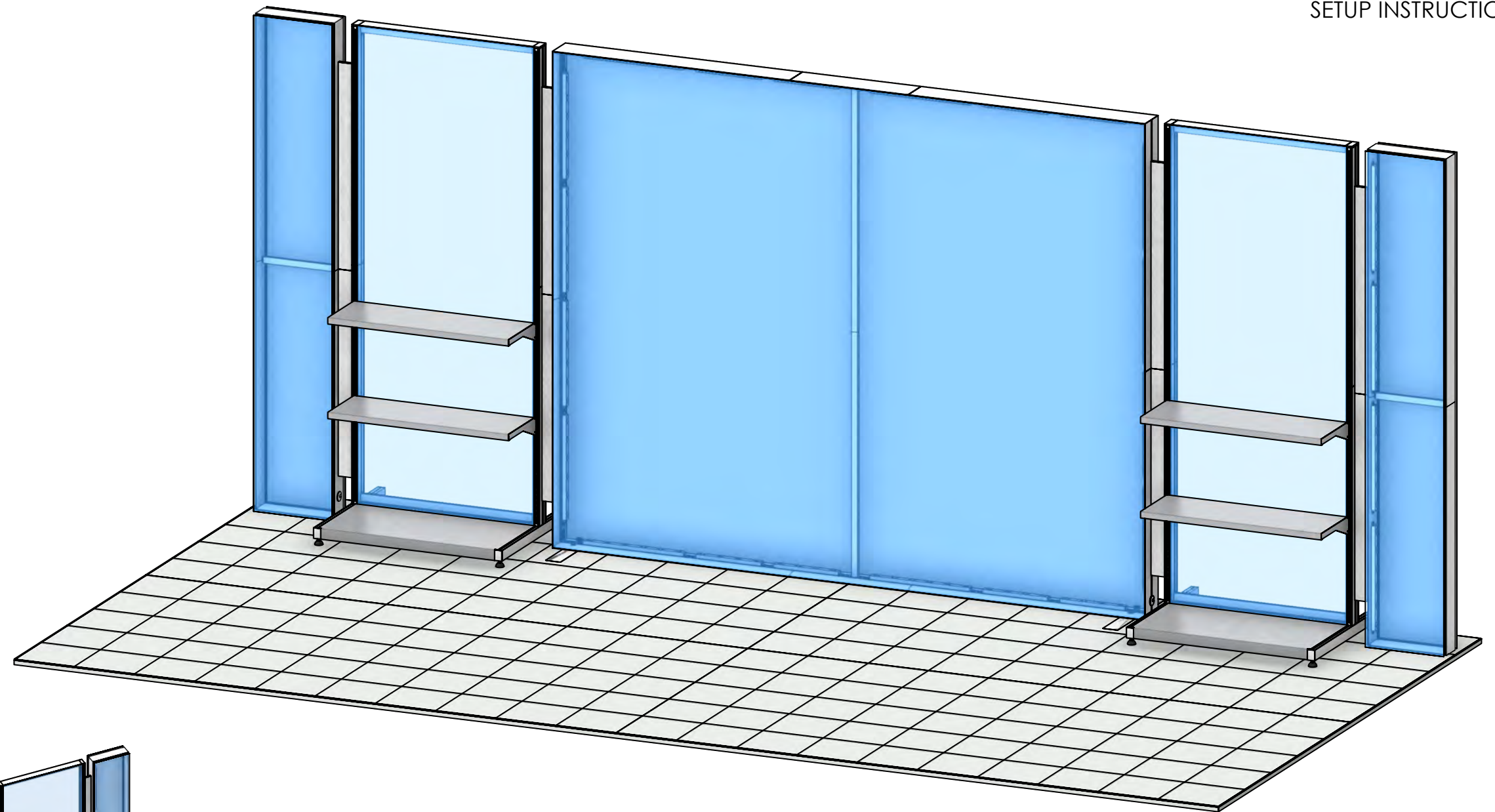

PROJECT BOM

SETUP#	HARDWARE	#	DESCRIPTION
A1	101-354-01-01-PW	2	354MM LENGTH OF PH1 POWDERCOATED EXTRUSION-WITH CAM LOCKS BOTH ENDS
A2	101-1184-01-02-PW	2	1184MM LENGTH OF PH1 POWDERCOATED EXTRUSION-WITH IB2 LOCK HOLES ONE SIDE-CAM LOCK ONE SIDE
A3	102-1000-68	8	1000MM LENGTH OF PH2 EXTRUSION-WITH SIDE LOCKS BOTH SIDES
A13	347-400-32-32	4	400MM (15.75in) LENGTH OF 347 SILVER EXTRUSION-WITH MITRE CUT BOTH ENDS
A14	347-1200-02-26-32	3	1200MM (47.24in) LENGTH OF 347 SILVER EXTRUSION-WITH MITRE CUT RIGHT END FOR CB10-IB2 LOCK HOLE LEFT END
A15	347-1200-02-61	1	1200MM (47.24in) LENGTH OF 347 SILVER EXTRUSION-WITH IB2 HOLE ONE RIGHT END-WITH MITRE LEFT END-WITH GROMMET HOLE 100MM FROM LEFT END
A16	347-1200-02-62	1	1200MM (47.24in) LENGTH OF 347 SILVER EXTRUSION-WITH IB2 HOLE ONE LEFT END-WITH MITRE RIGHT END-WITH GROMMET HOLE 1100MM FROM LEFT END
A17	347-1200-32-26-02	3	1200MM (47.24in) LENGTH OF 347 SILVER EXTRUSION-WITH MITRE CUT LEFT END FOR CB10-IB2 LOCK HOLE RIGHT END
A4	360-600-02-02	2	600MM (23.62in) LENGTH OF 360 BLAZE SILVER EXTRUSION-WITH IB2 LOCK HOLES BOTH ENDS
A5	360-1200-02-32	2	1200MM (47.24in) LENGTH OF 360 BLAZE SILVER EXTRUSION-WITH MITRE CUT FOR CB10s ONE END-IB2 LOCK HOLES ONE END
A6	360-1200-02-32 HOLE	2	1200MM (47.24in) LENGTH OF 360 BLAZE SILVER EXTRUSION-WITH MITRE CUT FOR CB10s ONE END-IB2 LOCK HOLES ONE END-WITH 9MM DIA THRU HOLES 90MM FROM LEFT END
A8	361-1200-02-32	2	1200MM (47.24in) LENGTH OF 361 BLAZE SILVER EXTRUSION-WITH MITRE CUT FOR CB10s ONE END-IB2 LOCK HOLES ONE END
A9	361-1200-02-32-05	2	1200MM (47.24in) LENGTH OF 361 BLAZE SILVER EXTRUSION-WITH MITRE CUT FOR CB10s ONE END-IB2 LOCK HOLES ONE END-WITH GROMMET HOLE- 76MM FROM LEFT/BOTTOM END
A12	824-750	4	750MM (29.53IN) LENGTH OF 824 CORNER POST EXTRUSION -WITH THRU HOLE FOR 3/8 BOLT, 38.1MM FROM END
824-EC	824-EC	1	5MM END CAP WITH SCREWS FOR 824 EXTRUSION
A10	830-1155	8	1155MM (45.47in) OF 830 SINGLE SIDED UPRIGHT OPEN EXTRUSION
830-EC	830-EC	5	7MM SEG PLASTIC END CAP FOR 830 EXTRUSION
A11	835-883-01-01	4	883MM (34.76in) OF 835 DOUBLE SIDED SEG EXTRUSION -WITH CAM LOCKS BOTH ENDS
BLZ-PLT-55	BLZ-PLT-550	2	Blaze foot with double countersunk holes, 3in x 550mm length
CB10	CB10	16	CB10 90 DEGREE CONNECTOR
FH-5/16-18	FH-5/16-18-1-1/4	4	ZINC-PLATED STEEL PHILLIPS FLAT HEAD SCREWS, 100 DEGREE COUNTERSINK, 5/16-18 THREAD, 1-1/4 LONG
IB2-O	IB2-O	17	JOINER BAR (OLD STYLE)
LED-EV-TH	LED-EV-THUMB-ORB	56	THUMB KNOB, ORBUS VERSION, FOR LED LIGHT BAR
LED-EV-W	LED-EV-WHT-6000-10	8	LIGHT BAR (SEG), AC POWER, 6000K, 14" L
LED-EV-W	LED-EV-WHT-6000-19	20	LIGHT BAR (SEG), AC POWER, 6000K, 21" L
MFY-DB-3	MFY-DB-36-17	2	36"W X 17"D DROP IN BASE WITH 2" TOE KICK
MFY-EPIN	MFY-EPIN	4	MODify Tapered Extension Pin, 5/16-18 thread
MFY-SLF-3	MFY-SLF-36-12	4	36"W X 12"D SHELF
SETUP#	GRAPHICS	#	DESCRIPTION
GR-A	HP-36-A-G	1	GRAPHIC (A) (19.63 w X 98.37 h total size) 15.63 w X 94.37 h finish size, Dye-sub print on Backlit Textile, single sided, sewn with silicone beading around perimeter & pull tab in bottom right corner
GR-B	HP-36-B-G	1	LINER (B) (19.63 w X 98.37 h total size) 15.63 w X 94.37 h finish size, Opaque Liner, sewn with FCE-2 silicone beading around perimeter & pull tab in bottom right corner
GR-C	HP-36-C-G	1	GRAPHIC (C) (39.26 w X 95.04 h total size) 35.26 w X 91.04 h finish size, Dye-sub print on Eclipse Blockout Stretch, single sided, sewn with FCE-2 silicone beading around perimeter & pull tab in bottom right corner (WITH 1/4" NOTCH LEFT & RIGHT BOTTOM HORIZONTAL SIDE CORNERS)
GR-D	HP-36-D-G	1	GRAPHIC (D) (121.99 w X 98.37 h total size) 117.99 w X 94.37 h finish size, Dye-sub print on Backlit Textile, single sided, sewn with silicone beading around perimeter & pull tab in bottom right corner
GR-E	HP-36-E-G	1	LINER (E) (121.99 w X 98.37 h total size) 117.99 w X 94.37 h finish size, Opaque Liner, sewn with FCE-2 silicone beading around perimeter & pull tab in bottom right corner
GR-F	HP-36-F-G	1	GRAPHIC (F) (39.26 w X 95.04 h total size) 35.26 w X 91.04 h finish size, Dye-sub print on Eclipse Blockout Stretch, single sided, sewn with FCE-2 silicone beading around perimeter & pull tab in bottom right corner (WITH 1/4" NOTCH LEFT & RIGHT BOTTOM HORIZONTAL SIDE CORNERS)
GR-G	HP-36-G-G	1	GRAPHIC (G) (19.63 w X 98.37 h total size) 15.63 w X 94.37 h finish size, Dye-sub print on Backlit Textile, single sided, sewn with silicone beading around perimeter & pull tab in bottom right corner

PROJECT BOM

FABRIC, VINYL & UV GRAPHIC CARE GUIDELINES

GENERAL HANDLING FABRIC GRAPHICS

- Your fabric graphics should always be handled in a clean, dry area with clean hands. When possible, use white fabric gloves.
- Be sure fabric is clean and dry before packing.
- Machine washing and/or drying is not recommended for all fabrics. Refer to the chart below for which fabrics are washable.

EMERGENCY STAIN TREATMENT (FABRIC)

- For dry stains, like loose dirt or pencil marks, try initially using masking tape or Magic Eraser (dry-not moistened).
- Introduce water or liquids to treat stains, if at all possible, treat the stain with fabric off of the frame.

- Place a clean dry cloth behind stain (to absorb stains while being treated). Moisten another cloth initially with just water (distilled water is optimal, if available).
- Gently blot stain with moistened cloth (or small area of moistened Magic Eraser), while trying to push stain through to the back, using the dry cloth to absorb.
- Repeat using care to keep the wet area as small as possible.
- Grandma's Secret Spot remover can be an effective stain remover. Mix several drops in a small cup with clean water. Repeat above and using dry cloth on back of stain to absorb.

MACHINE WASHING FABRIC GRAPHICS

- Cold water/delicate cycle/tumble dry low or air dry. For stretch fabrics do not use dryer, let hang dry.
- Use caution on dryer time with graphics containing liners. Its best to put tension fabric on frame when fabric is still damp and let it air dry. Always be sure that the aluminum frame is clean when mounting the damp graphic.
- Fabric stretch graphics that washed and machine dried may shrink up to 3/4" per every 50" of fabric in the direction of the stretch and shrink up to 1/4" in non stretch direction.

STORING & PACKING BACKLIT GRAPHICS

- To avoid cracks in the ink or having to steam graphics, Backlit fabrics should be loosely folded with bubble wrap or stored around a tube.
- Avoid folding the graphic tightly to store in a small bag or box.

GENERAL HANDLING VINYL & UV GRAPHICS

- Vinyl banners and rigid graphics should always be handled in a clean, dry area with clean hands. When possible, use white fabric gloves.
- Be sure vinyl/ UV is clean and dry before packing. Always follow material handling and packing instructions included.
- All vinyl material should be rolled with graphic facing into protect the graphic printed side. Roll on a tube in available.
- Avoid folding material to reduce the risk of crease lines and chipped inks. If a graphic must be folded, try and fold loosely and as few times as possible.

EMERGENCY STAIN TREATMENT (UV)

- For drier stains, like loose dirt, pencil marks or adhesive, try initially using masking tape, Masking tape can be quite effective at lifting dry surface dirt. Try 'pulling' as much of stain away as you can and avoid rubbing the stain into the material.
- While using Windex® avoid scrubbing harshly. Too much pressure can fade the graphic print.

GENERAL HANDLING OF ROLLABLE PVC PANELS

All mural panels, truss panels and detachables should be rolled with the graphic facing out to protect the graphic printed side. Mural panels should be stored in the original plastic sleeves that are provided with the panels.

STEAMING FABRIC GRAPHICS

- For optimal results, steam wrinkles when fabric is tensioned and installed securely on the frame.
- Fill steamer with clean drinking water or distilled water. Avoid using water containing hard minerals.
- Hold steamer upright and hold close to fabric. Avoid touching fabric with steamer.
- Do not top steamer as water drips may cause water marks to form on graphic

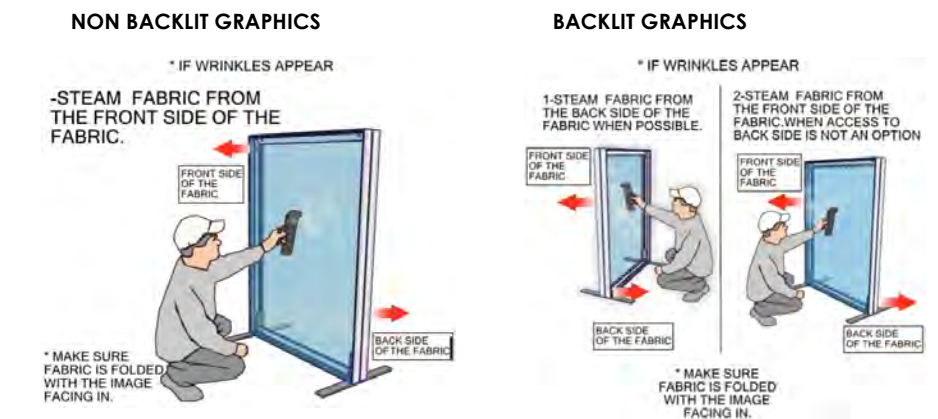

FABRIC	WASHING MACHINE	DRY CLEAN	SPOT CLEAN	STEAMING / IRON	MAGIC ERASER
RESILIENCE	NO	NO	NO	NO	YES (ONLY ON WHITE)
OXFORD	YES	YES	YES	YES	YES
POWER STRETCH	YES	YES	YES	YES	YES
DISPLAY POLYESTER	YES	YES	YES	YES	YES
DISPLY POLY TABLE THROWS	YES	YES	YES	YES	YES
OUTDOOR FLAG	YES (MUST VELCRO THE TABS)	N/A (MUST VELCRO THE TABS)	YES	YES	YES
CANVAS OUTDOOR	NO	NO	YES	STEAM ONLY	YES
CANVAS LIGHTBOX	NO	NO	NO	STEAM ONLY	YES
AGILITY	YES	YES	YES	(ONLY W/ 100% TENSION)	YES
SUPER STRETCH	YES	YES	YES	(ONLY W/ 100% TENSION)	YES
TRIPLE WHITE	YES	YES	NO	YES	NO
ECLIPSE	NO	NO	YES	STEAM ONLY	YES
SOFT KNIT	YES	YES	YES	YES	YES
SHEER	YES	YES	YES	YES	YES
VINYL & ROLLABLE					
	SOLVENT	SOAPY WATER (Dawn)	WINDEX		
FLATMAXX	ONLY ON WHITE	YES	NO		
SCRIM 13OZ/ 18OZ	ONLY ON WHITE	YES	NO		
VINLY 20OZ	ONLY ON WHITE	YES	NO		
MELINEX	NO	YES	NO		
MURAL PANELS	NO	YES	YES		
UV RIDGED	NO	YES	YES		

SET-UP NOTES

Redesign of this exhibit without approval by Orbus may result in dangerous and unsafe structures. Nimlok disclaims any responsibility for redesigned exhibits it does not approve in writing.





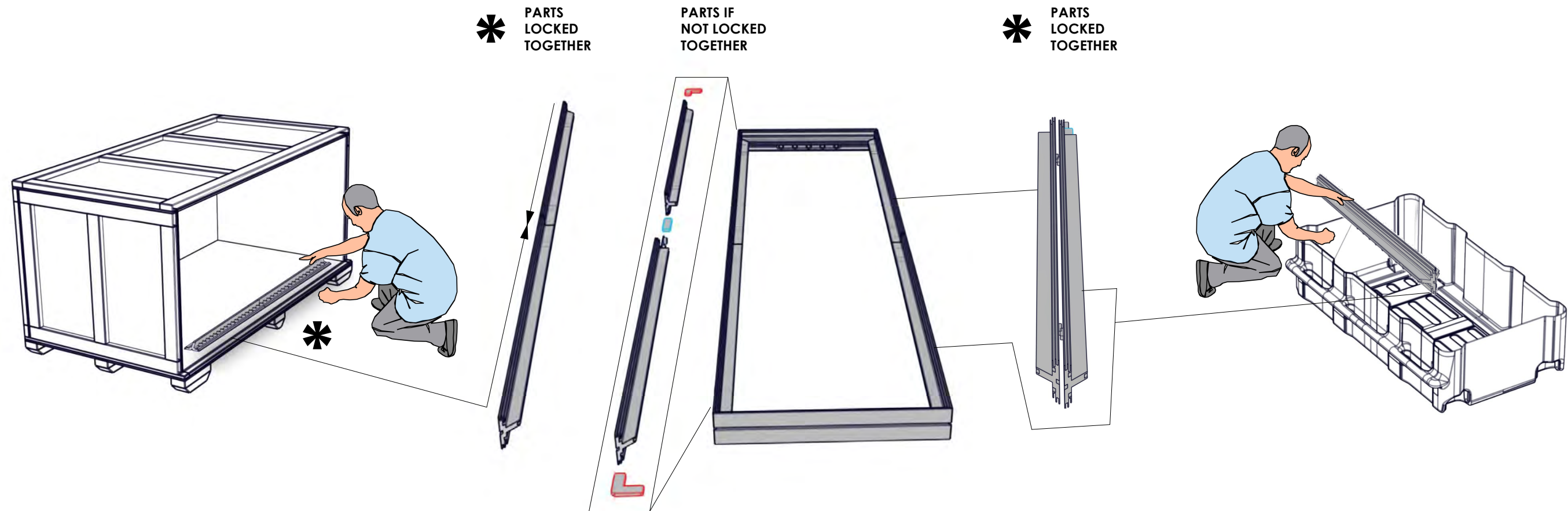

Parts and components such as panels and extrusions are manufactured to metric sizing. Where ever possible sizes have been noted in feet and inches as well as in metric. Below is the imperial to metric sizing table for reference. "Nominal" refers to approximate size.

NOTE: PARTS MAY COME PRE-ASSEMBLED FOR PACKING PURPOSES.



METRIC TO IMPERIAL DIMENSION

2400mm = (94.50")	1200mm = (47.25")
2100mm = (82.67")	900mm = (35.50")
1800mm = (70.87")	600mm = (23.62")
1500mm = (59.05")	300mm = (11.81")

-  Internet Connection
  Phone Line
-  Main Electric Drop (Point Of Distribution)
-  Electrical Outlet
  Sharp Edges
-  Cables Under Carpet

HELPFUL SETUP QR CODES



**SCAN QR CODES
WITH YOUR PHONE
CAMERA**

6096mm
[240.000"]

3048mm
[120.000"]

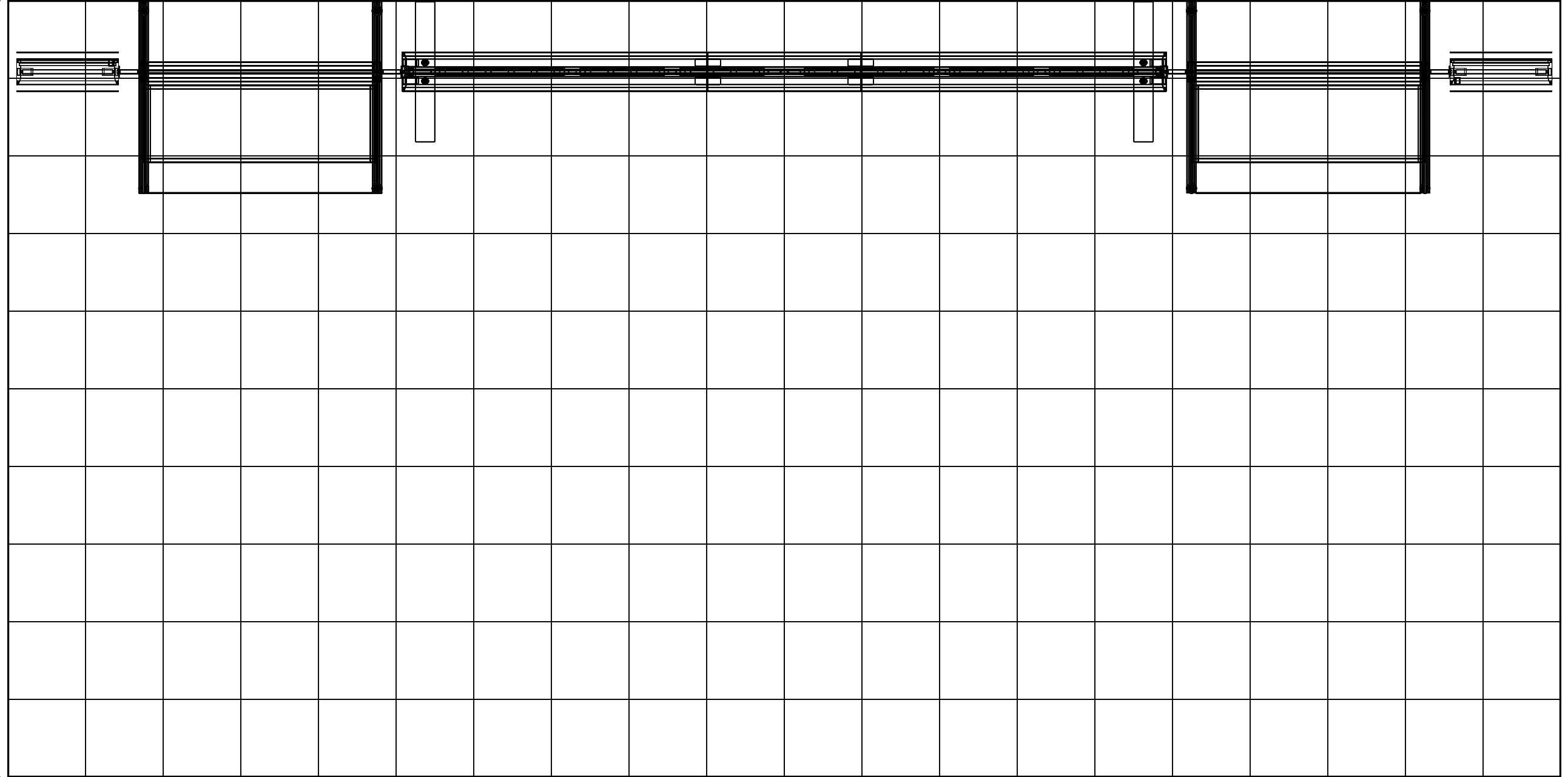

LED Lights

How to replace an LED light fixture.

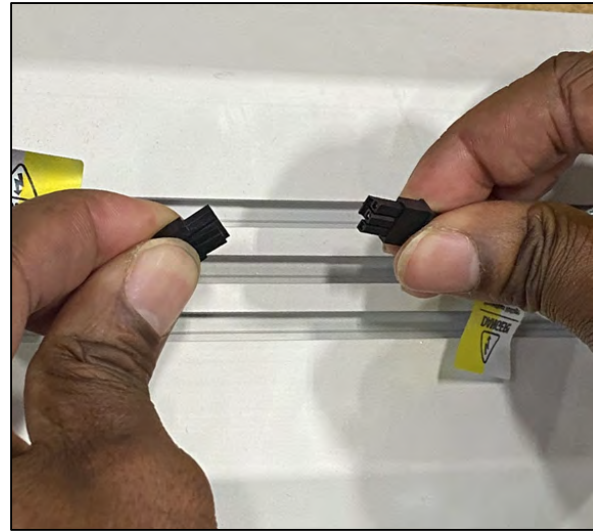

STEP-1

Disconnect the lead at both ends of the LED fixture as shown. Take note of male and female ends.

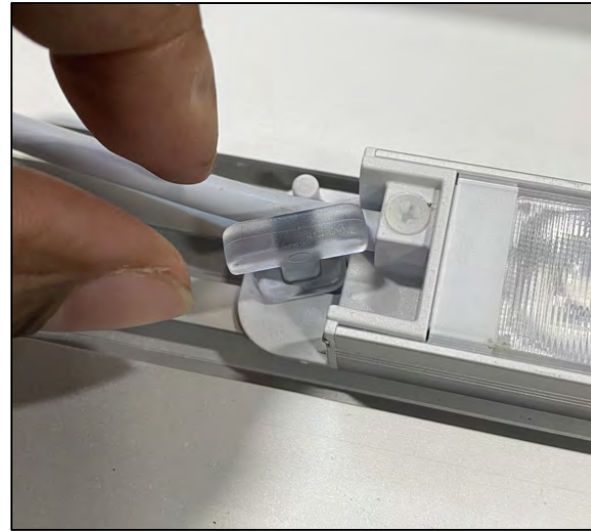

STEP-2

Rotate the twist clips 90 degrees at both ends to unlock and remove the fixture from the extrusion.

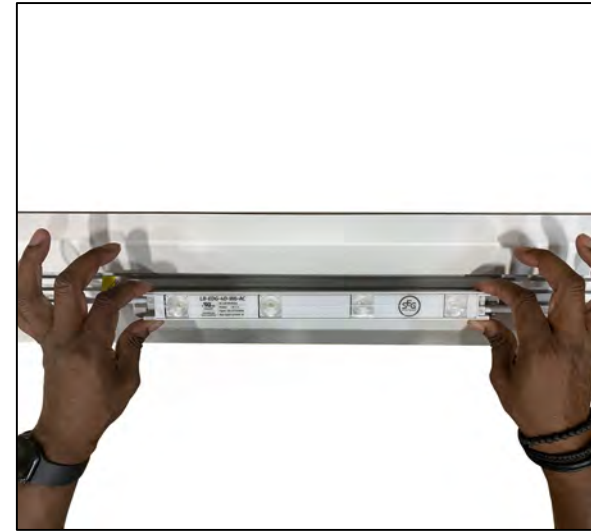

STEP-3

Remove and replace the LED light. Be sure to match the proper male and female connectors to existing LED lights.

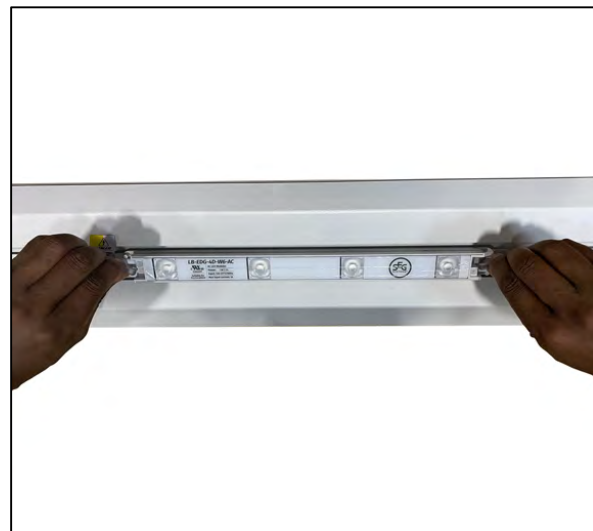

STEP-4

Secure the replacement LED light with twist clips on both ends.



STEP-5

Connect replacement LED light with existing lights.

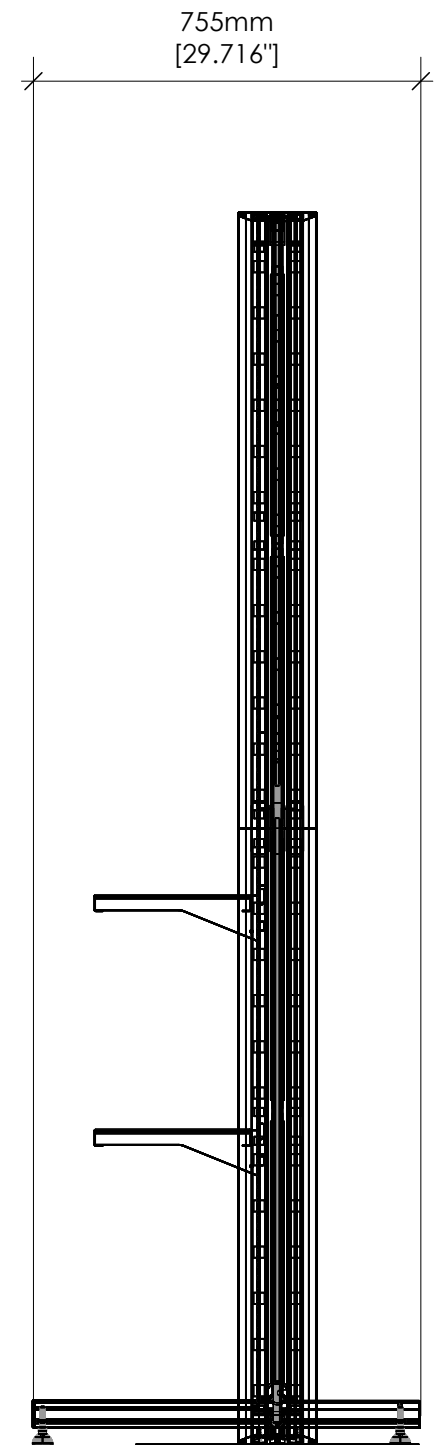

SETUP#	#	DESCRIPTION
CB10	8	CB10 90 DEGREE CONNECTOR
A6	2	1200MM (47.24in) LENGTH OF 360 BLAZE SILVER EXTRUSION-WITH MITRE CUT FOR CB10s ONE END-IB2 LOCK HOLES ONE END-WITH 9MM DIA THRU HOLES 90MM FROM LEFT END
IB2-O	13	JOINER BAR (OLD STYLE)
A9	2	1200MM (47.24in) LENGTH OF 361 BLAZE SILVER EXTRUSION-WITH MITRE CUT FOR CB10s ONE END-IB2 LOCK HOLES ONE END-WITH GROMMET HOLE- 76MM FROM LEFT/BOTTOM END
A5	2	1200MM (47.24in) LENGTH OF 360 BLAZE SILVER EXTRUSION-WITH MITRE CUT FOR CB10s ONE END-IB2 LOCK HOLES ONE END
FH-5/16-18	4	ZINC-PLATED STEEL PHILLIPS FLAT HEAD SCREWS, 100 DEGREE COUNTERSINK, 5/16-18 THREAD, 1-1/4 LONG
BLZ-PLT-55	2	Blaze foot with double countersunk holes, 3in x 550mm length
A8	2	1200MM (47.24in) LENGTH OF 361 BLAZE SILVER EXTRUSION-WITH MITRE CUT FOR CB10s ONE END-IB2 LOCK HOLES ONE END
A2	2	1184MM LENGTH OF PH1 POWDERCOATED EXTRUSION-WITH IB2 LOCK HOLES ONE SIDE-CAM LOCK ONE SIDE
A4	2	600MM (23.62in) LENGTH OF 360 BLAZE SILVER EXTRUSION-WITH IB2 LOCK HOLES BOTH ENDS

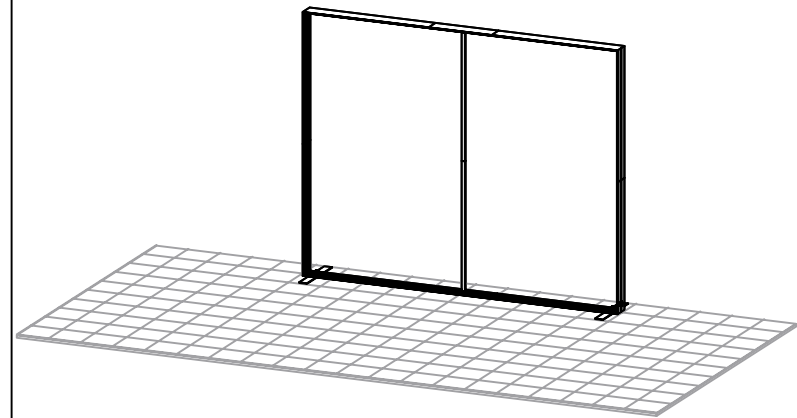

COMPONENTS IN THIS STEP:
(Not to scale)

360	361	101 (PH1)

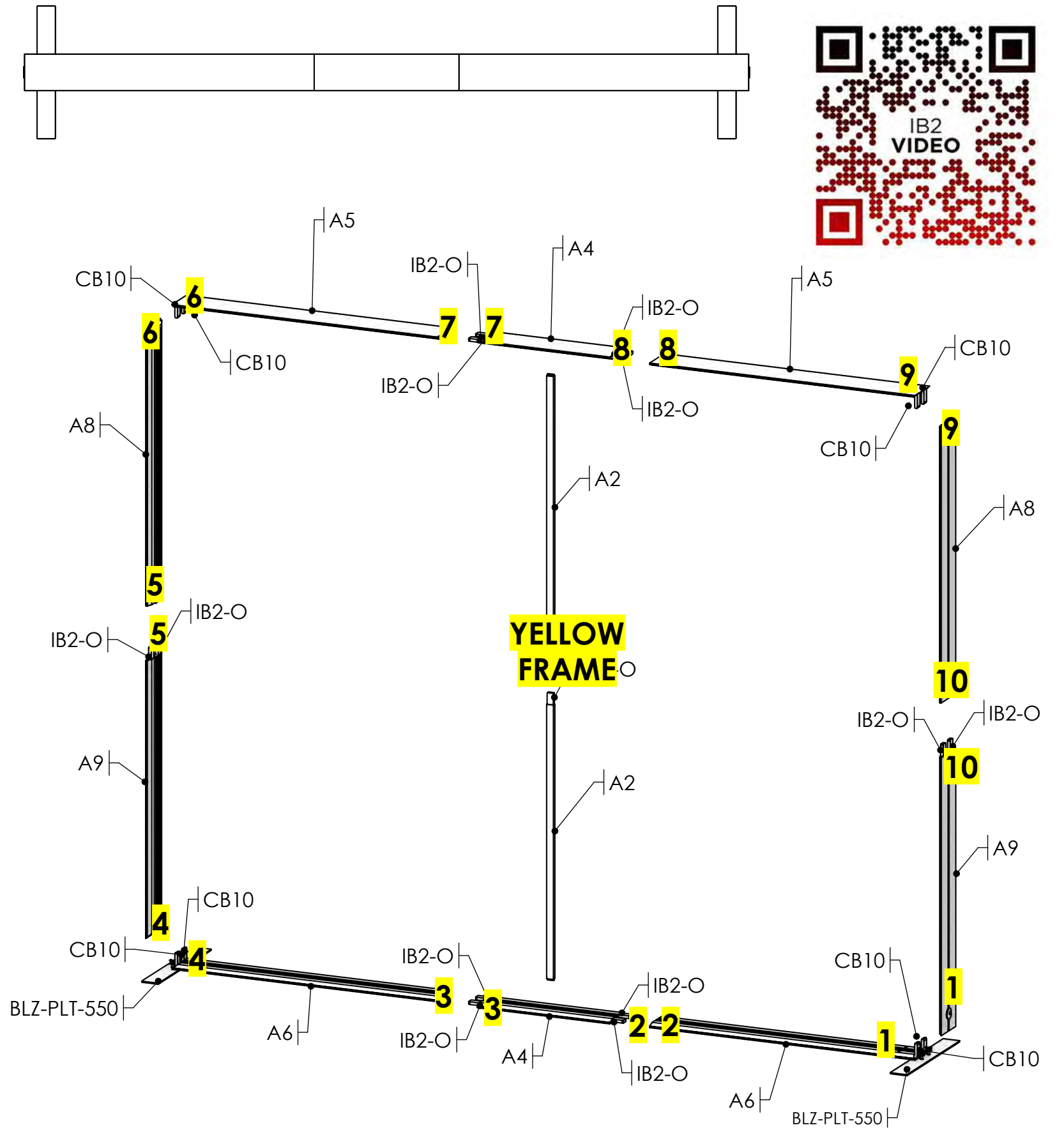
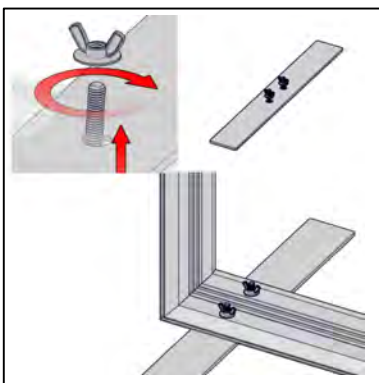
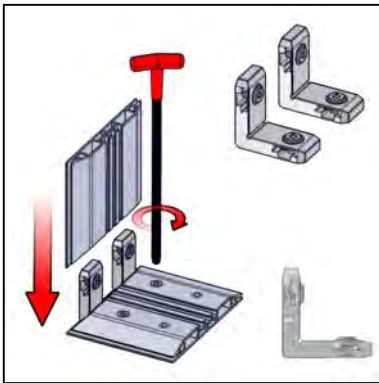
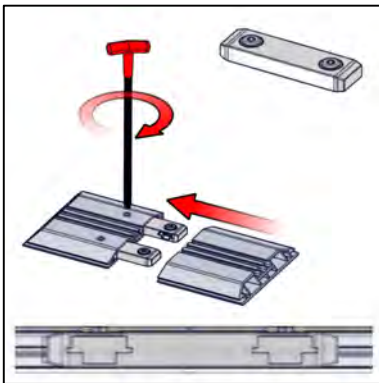
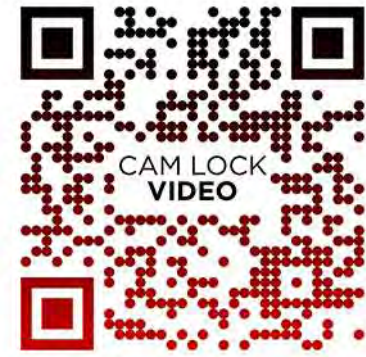

SETUP#	#	DESCRIPTION
MFY-EPIN	4	MODify Tapered Extension Pin, 5/16-18 thread
A10	8	1155MM (45.47in) OF 830 SINGLE SIDED UPRIGHT OPEN EXTRUSION
A12	4	750MM (29.53IN) LENGTH OF 824 CORNER POST EXTRUSION -WITH THRU HOLE FOR 3/8 BOLT, 38.1MM FROM END
824-EC	1	5MM END CAP WITH SCREWS FOR 824 EXTRUSION

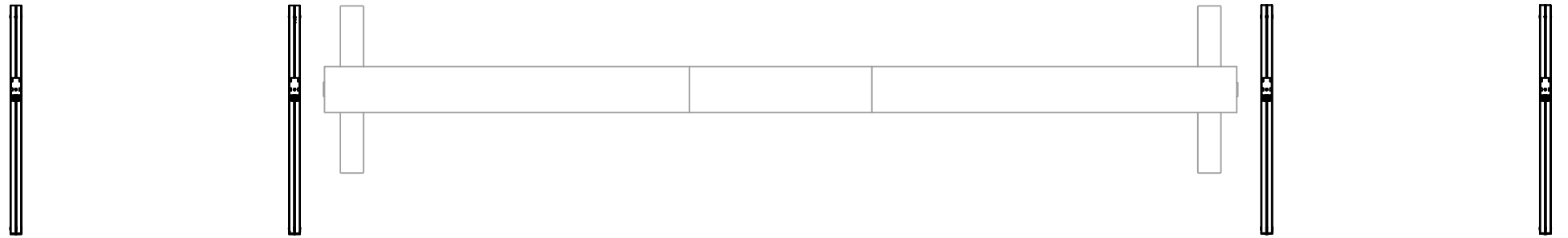

BUILD 4 UPRIGHTS

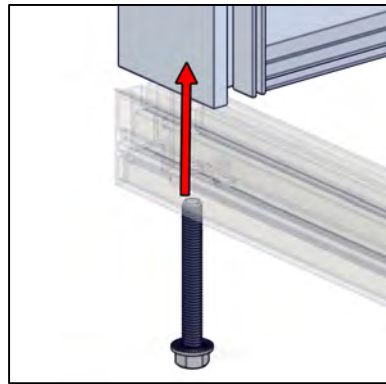

MFY-BOLT-375-16-2.5

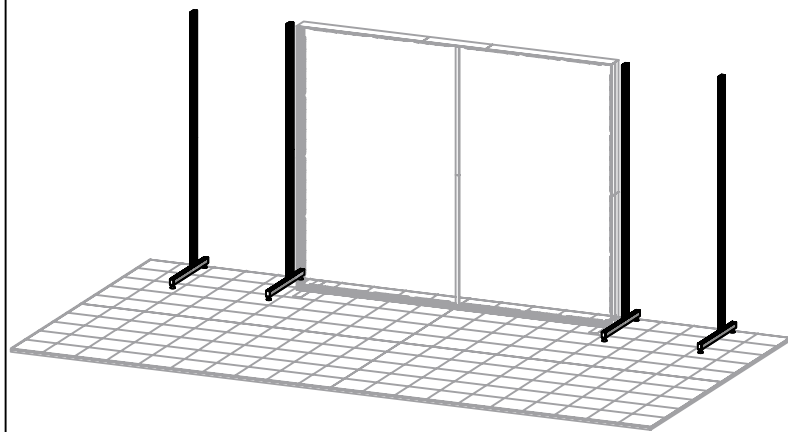
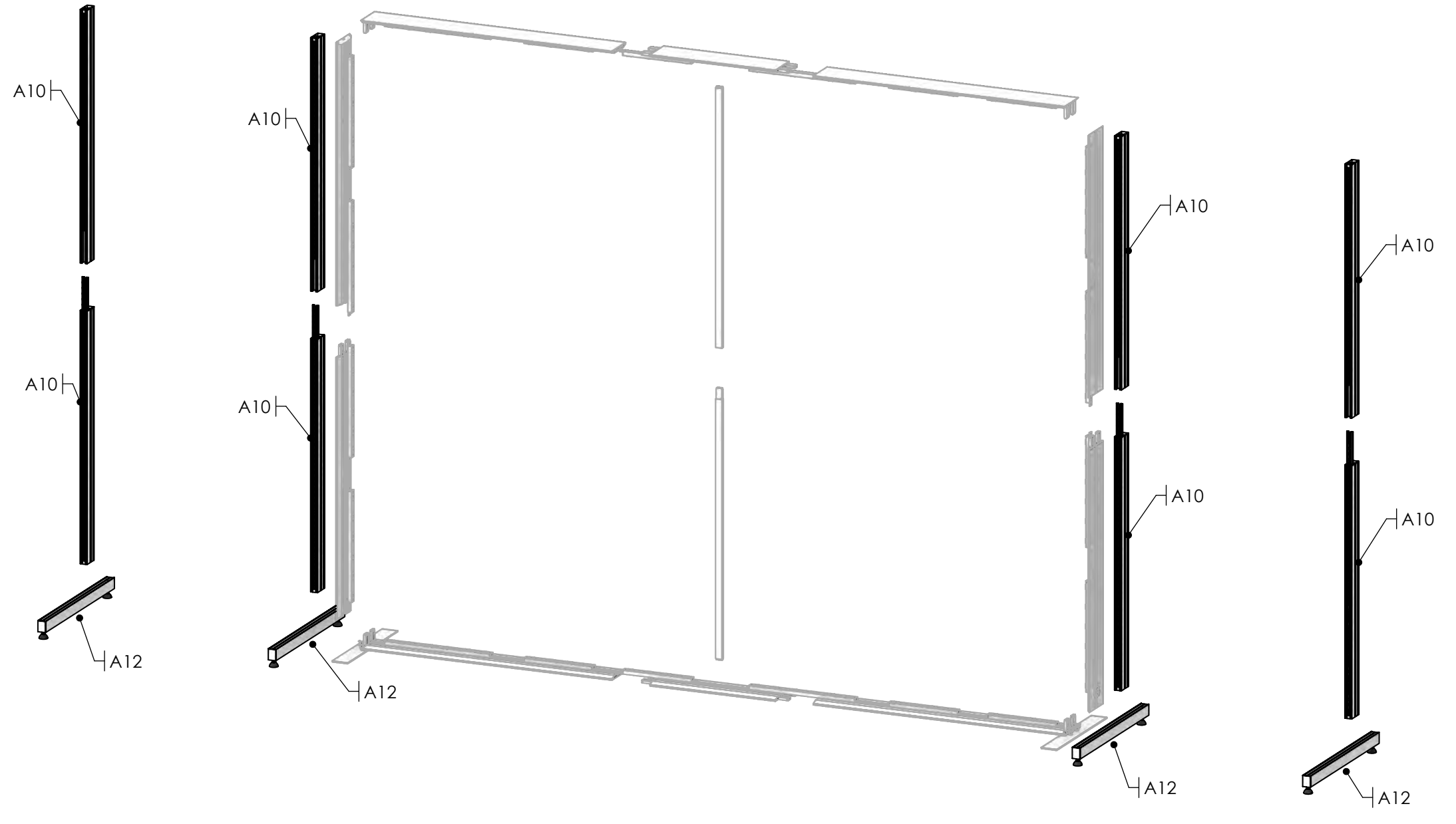
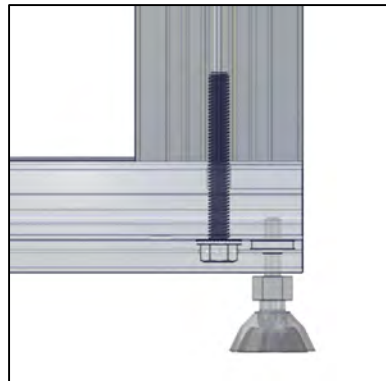

COMPONENTS
IN THIS STEP:
(Not to scale)

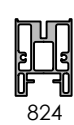

SETUP#	#	DESCRIPTION
A11	4	883MM (34.76in) OF 835 DOUBLE SIDED SEG EXTRUSION -WITH CAM LOCKS BOTH ENDS
830-EC	5	7MM SEG PLASTIC END CAP FOR 830 EXTRUSION



ASSEMBLE 2 UNITS

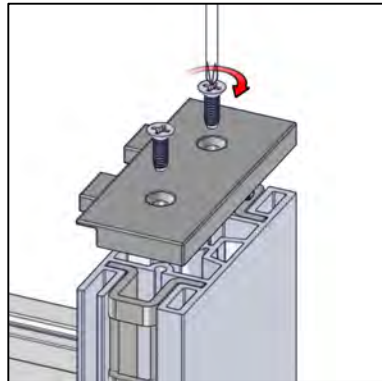

LOOSEN END CAP TO ATTACH TOP CROSS BRACE

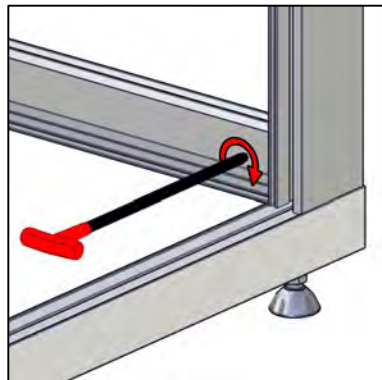

CROSS BRACE SITS ON SUPPORT LEGS

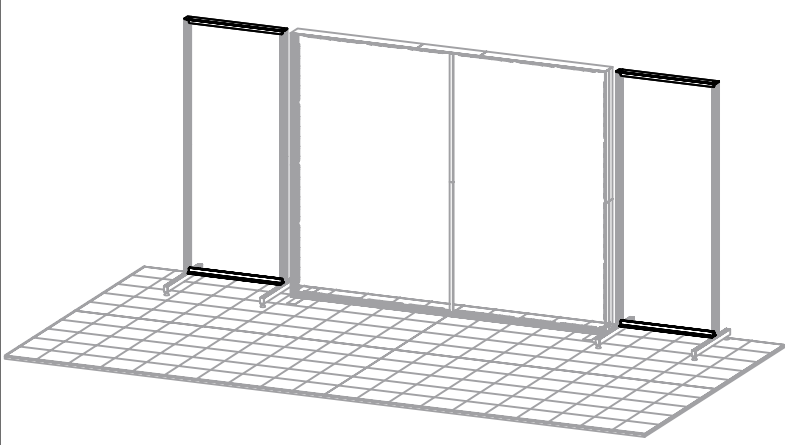
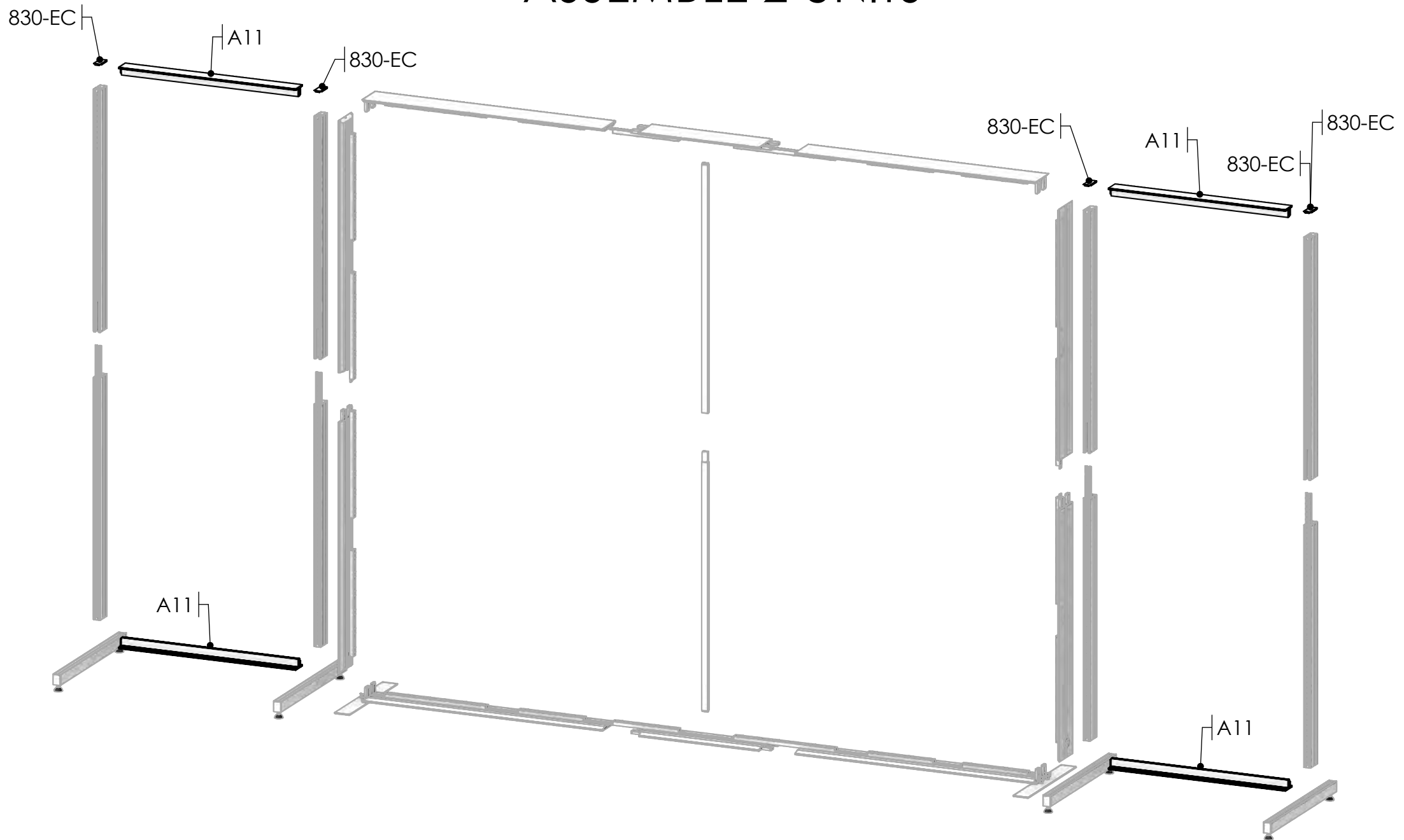

COMPONENTS
IN THIS STEP:
(Not to scale)

SETUP#	#	DESCRIPTION
A3	8	1000MM LENGTH OF PH2 EXTRUSION-WITH SIDE LOCKS BOTH SIDES

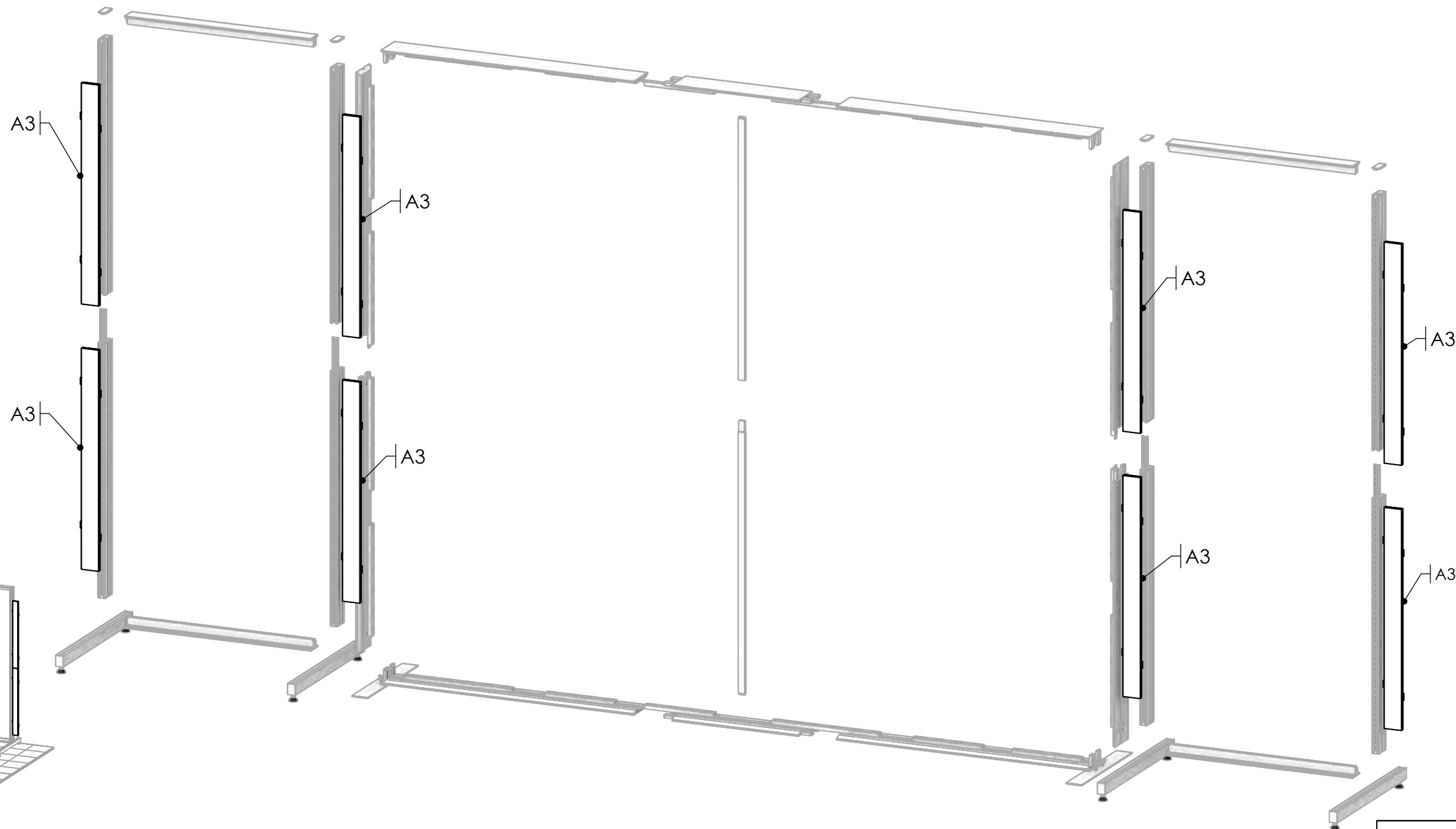
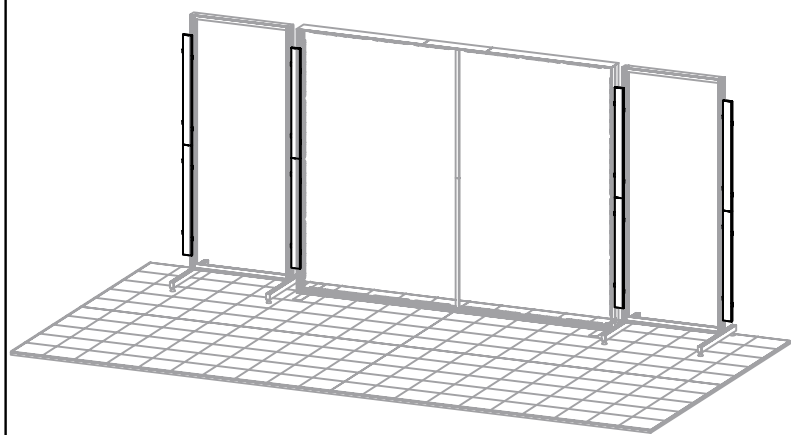
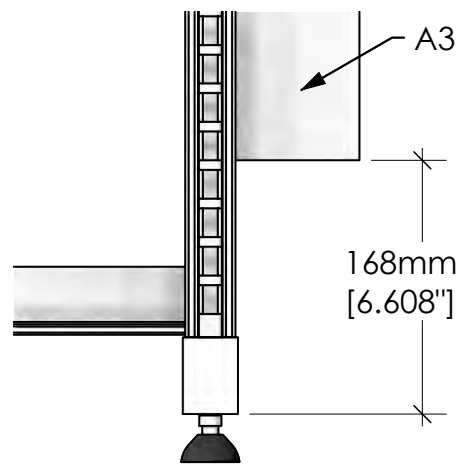
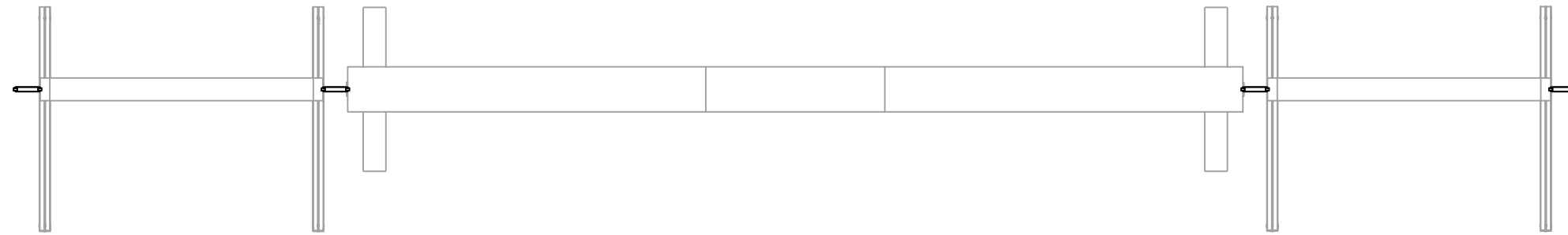

COMPONENTS
IN THIS STEP:
(Not to scale)



102 (PH2)

LED Lights

Installing the LED light fixtures.

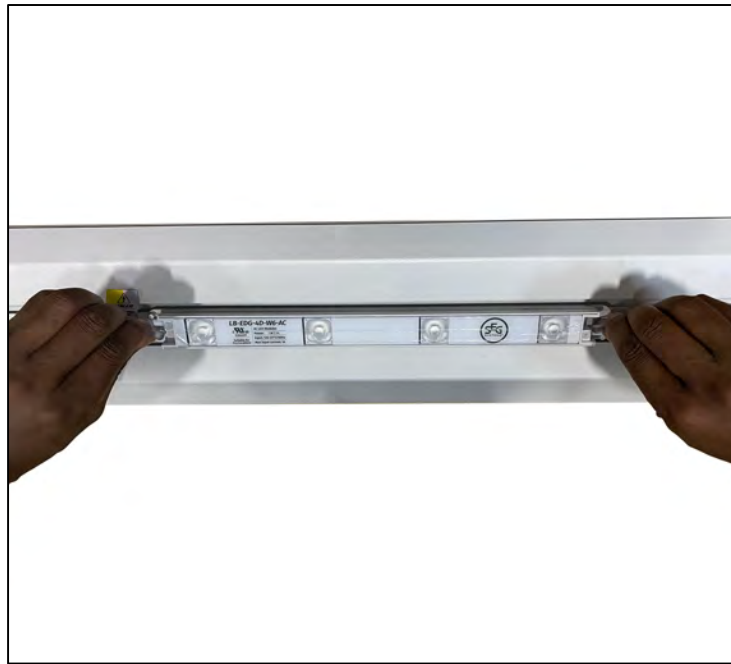

STEP-1

Secure the LED lights with twist clips on both ends.

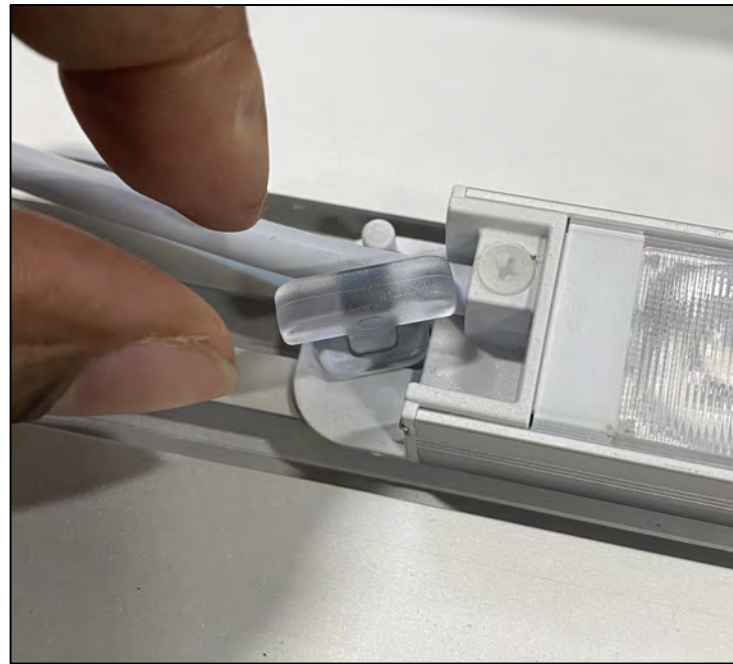

STEP-2

Rotate the twist clips 90 degrees at both ends to secure to the extrusion.

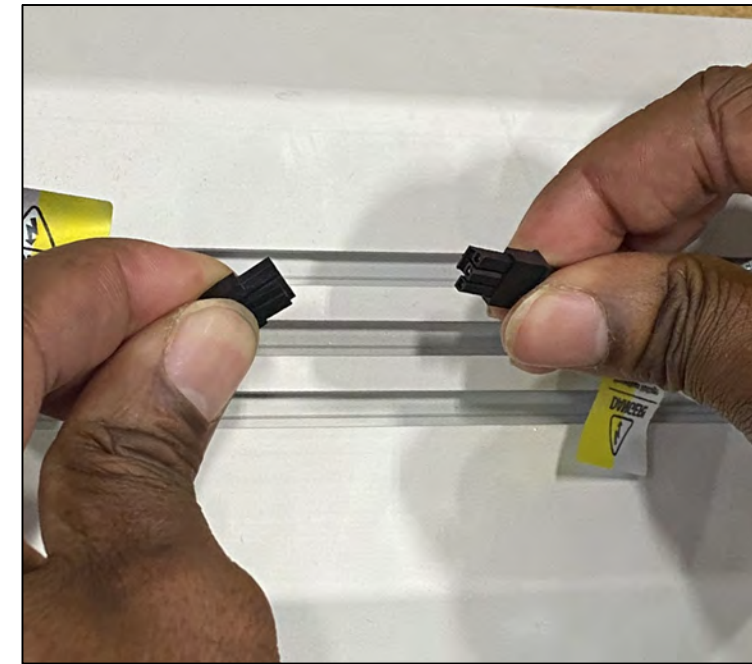

STEP-3

Connect the lead at both ends of the LED fixture as shown. Take note of male and female ends.

SETUP#	#	DESCRIPTION
A1	2	354MM LENGTH OF PH1 POWDERCOATED EXTRUSION-WITH CAM LOCKS BOTH ENDS
CB10	8	CB10 90 DEGREE CONNECTOR
A13	4	400MM (15.75in) LENGTH OF 347 SILVER EXTRUSION-WITH MITRE CUT BOTH ENDS
IB2-O	4	JOINER BAR (OLD STYLE)
A14	3	1200MM (47.24in) LENGTH OF 347 SILVER EXTRUSION-WITH MITRE CUT RIGHT END FOR CB10-IB2 LOCK HOLE LEFT END
A17	3	1200MM (47.24in) LENGTH OF 347 SILVER EXTRUSION-WITH MITRE CUT LEFT END FOR CB10-IB2 LOCK HOLE RIGHT END
A15	1	1200MM (47.24in) LENGTH OF 347 SILVER EXTRUSION-WITH IB2 HOLE ONE RIGHT END-WITH MITRE LEFT END-WITH GROMMET HOLE 100MM FROM LEFT END
A16	1	1200MM (47.24in) LENGTH OF 347 SILVER EXTRUSION-WITH IB2 HOLE ONE LEFT END-WITH MITRE RIGHT END-WITH GROMMET HOLE 1100MM FROM LEFT END

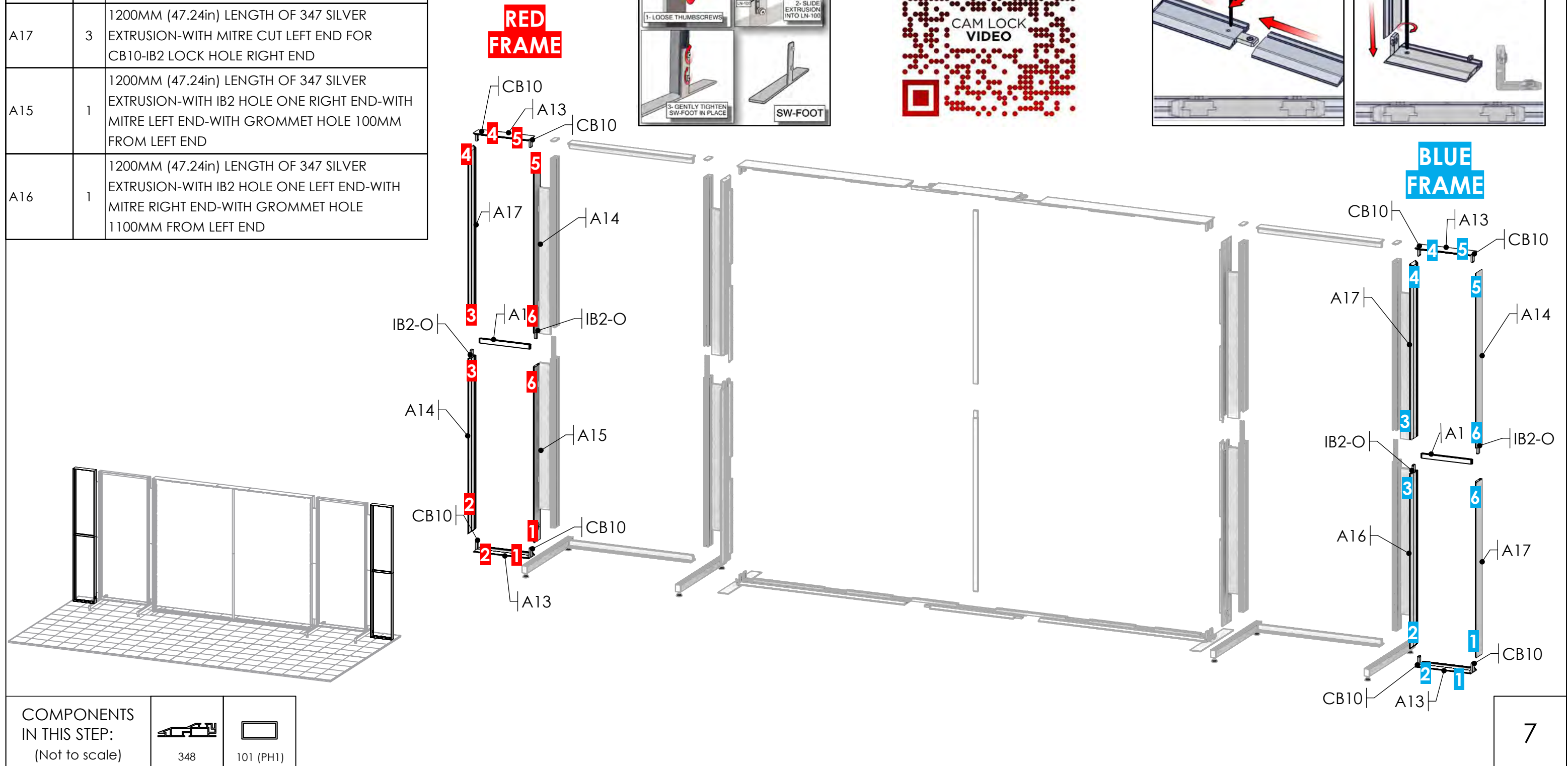
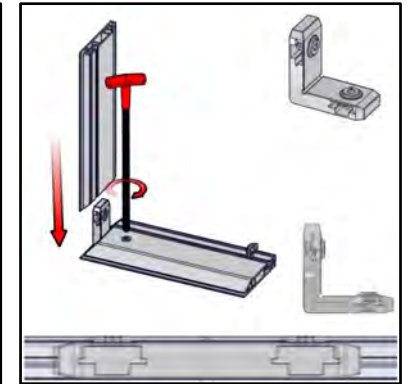
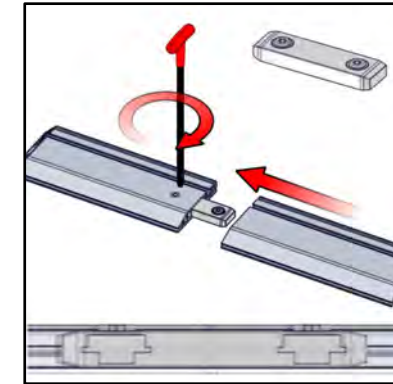
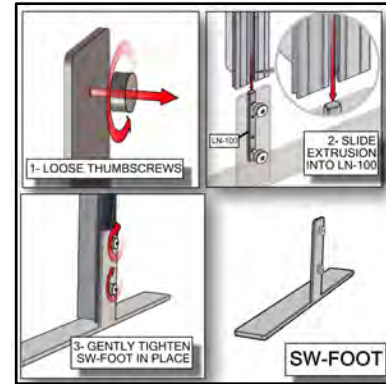
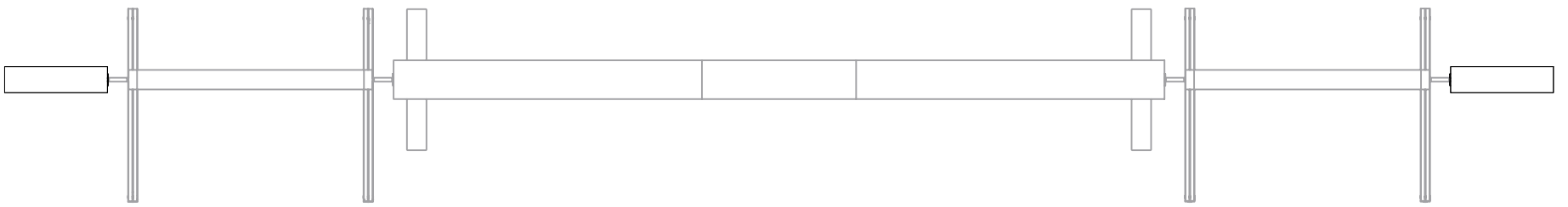

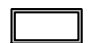
COMPONENTS IN THIS STEP: (Not to scale)	 348	 101 (PH1)
--	---	---

SETUP#	#	DESCRIPTION
GR-B	1	LINER (B) (19.63 w X 98.37 h total size) 15.63 w X 94.37 h finish size, Opaque Liner, sewn with FCE-2 silicone beading around perimeter & pull tab in bottom right corner
GR-H	1	LINER (H) (19.63 w X 98.37 h total size) 15.63 w X 94.37 h finish size, Opaque Liner, sewn with FCE-2 silicone beading around perimeter & pull tab in bottom right corner
GR-E	1	LINER (E) (121.99 w X 98.37 h total size) 117.99 w X 94.37 h finish size, Opaque Liner, sewn with FCE-2 silicone beading around perimeter & pull tab in bottom right corner

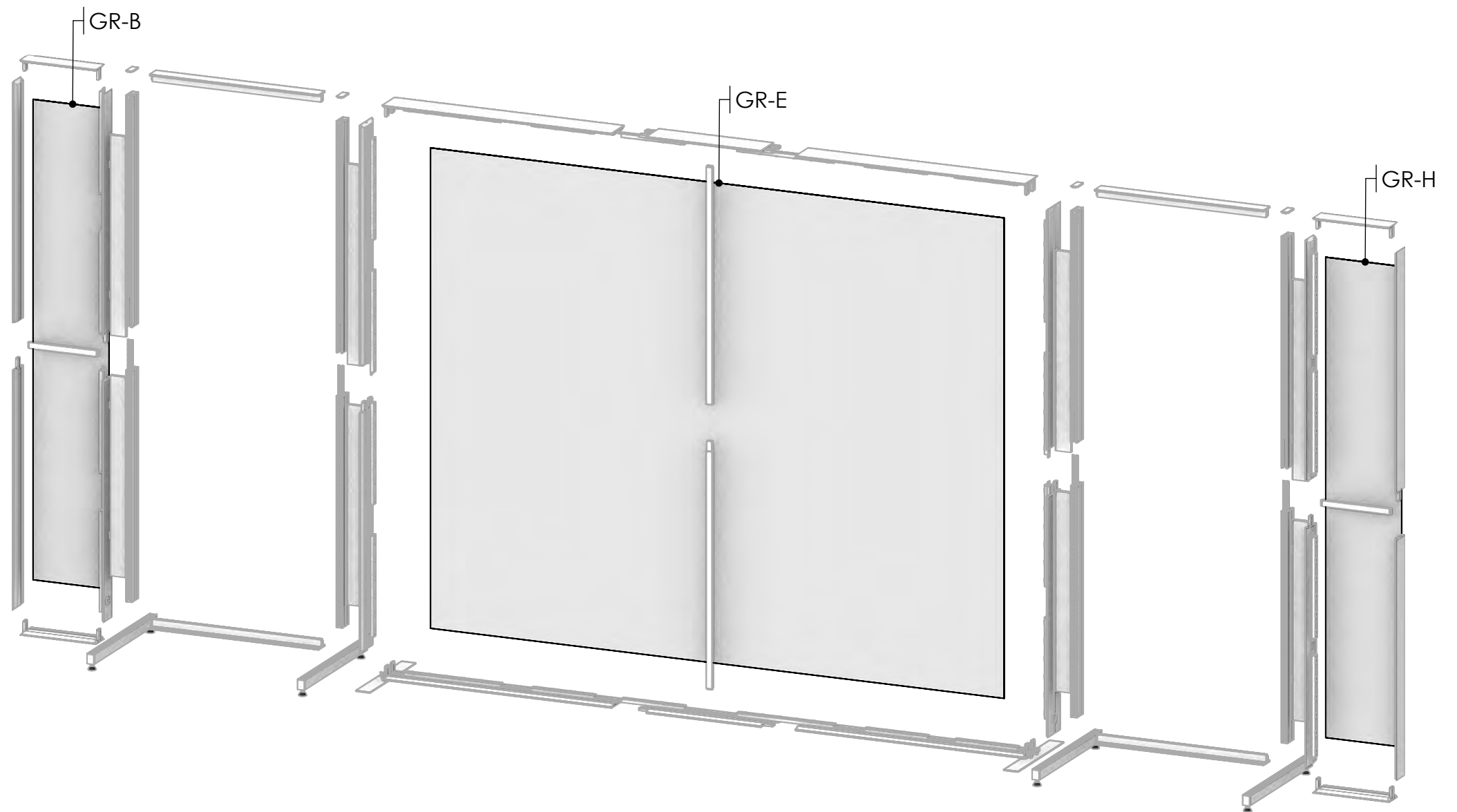
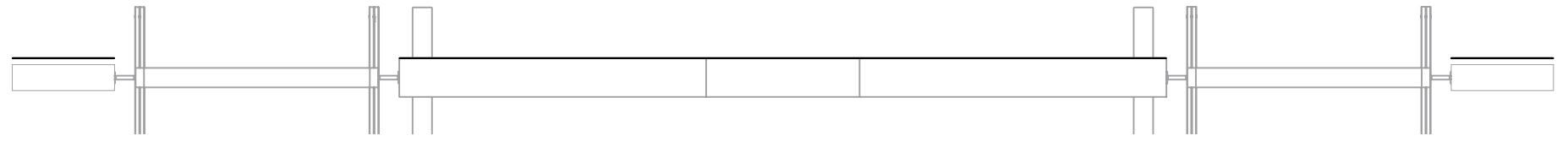

SETUP#	#	DESCRIPTION
GR-C	1	GRAPHIC (C) (39.26 w X 95.04 h total size) 35.26 w X 91.04 h finish size, Dye-sub print on Eclipse Blockout Stretch, single sided, sewn with FCE-2 silicone beading around perimeter & pull tab in bottom right corner (WITH 1/4" NOTCH LEFT & RIGHT BOTTOM HORIZONTAL SIDE CORNERS)
GR-A	1	GRAPHIC (A) (19.63 w X 98.37 h total size) 15.63 w X 94.37 h finish size, Dye-sub print on Backlit Textile, single sided, sewn with silicone beading around perimeter & pull tab in bottom right corner
GR-F	1	GRAPHIC (F) (39.26 w X 95.04 h total size) 35.26 w X 91.04 h finish size, Dye-sub print on Eclipse Blockout Stretch, single sided, sewn with FCE-2 silicone beading around perimeter & pull tab in bottom right corner (WITH 1/4" NOTCH LEFT & RIGHT BOTTOM HORIZONTAL SIDE CORNERS)
GR-G	1	GRAPHIC (G) (19.63 w X 98.37 h total size) 15.63 w X 94.37 h finish size, Dye-sub print on Backlit Textile, single sided, sewn with silicone beading around perimeter & pull tab in bottom right corner
GR-D	1	GRAPHIC (D) (121.99 w X 98.37 h total size) 117.99 w X 94.37 h finish size, Dye-sub print on Backlit Textile, single sided, sewn with silicone beading around perimeter & pull tab in bottom right corner

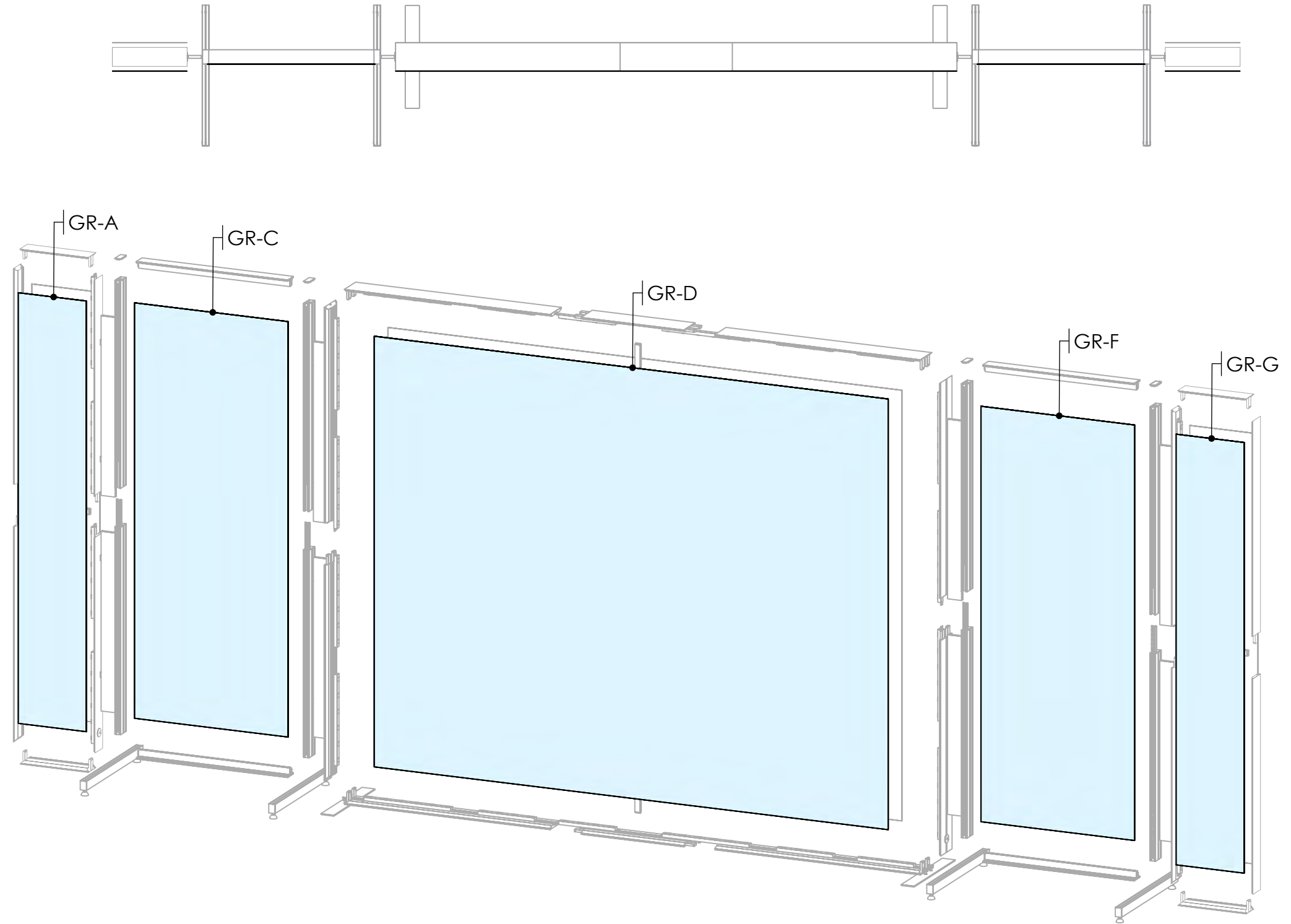

SETUP#	#	DESCRIPTION
MFY-DB-36	2	36"W X 17"D DROP IN BASE WITH 2" TOE KICK
MFY-SLF-36	4	36"W X 12"D SHELF

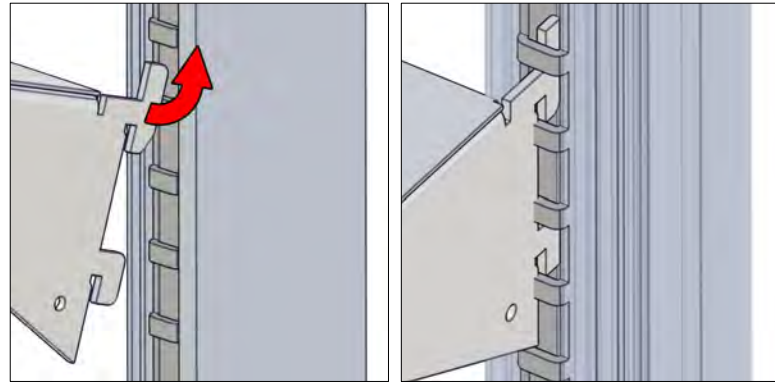

RAISE AND HOOK SHELF INTO PLACE
**START WITH BOTTOM SHELVES.

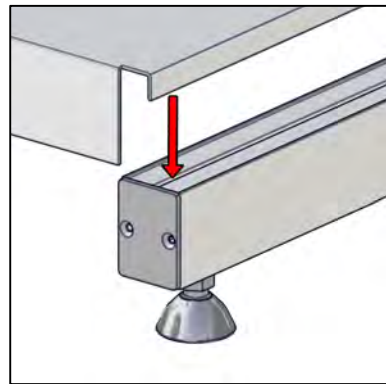

MFY-36-17-BASE-PAN
PLACE BASE PAN
IN GROOVE(FOOT)

